

|                |                |      |                 |         |           |          |           |
|----------------|----------------|------|-----------------|---------|-----------|----------|-----------|
| Revision Level |                |      | Revision Record | Changed | Date      | Approved | Date      |
| Drawing        | State          | Part |                 |         |           |          |           |
| 00.0           | Design Release | -    | SEE ECN# 014730 | TAT     | 11/5/2018 | EJH      | 11/5/2018 |

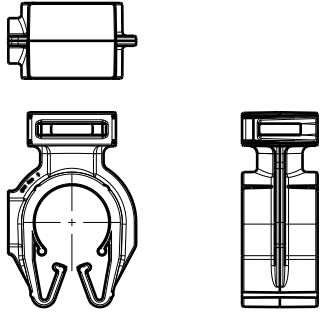
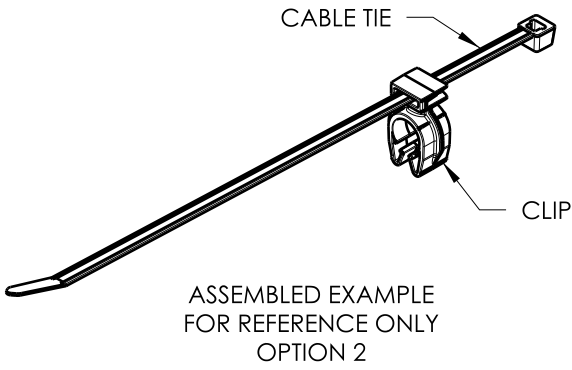
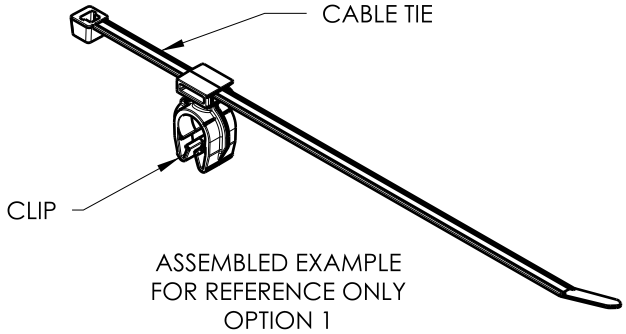

MOC10SAD  
DELIVERY CONDITION: UNASSEMBLED SET  
SCALE 1:1

| TYPE           | SUGGESTED DIAMETER RANGE* |
|----------------|---------------------------|
| HARNESS        | 10.0MM-11.5MM             |
| HOSE           | 9.5MM-11.5MM              |
| HARD PIPE/TUBE | 10.0MM-11.5MM             |

\*RECOMMENDED SIZES MAY DIFFER DEPENDING ON THE APPLICATION, PRODUCT REQUIREMENTS AND MATERIALS USED

\*\*PATENT PENDING 29/582,271

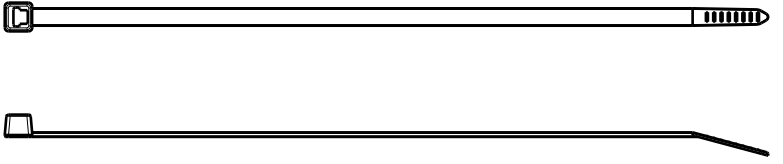

T50R  
DELIVERY CONDITION: UNASSEMBLED SET

| GLOBAL PART DESCRIPTION         | BUNDLE RANGE | CABLE TIE    |             |       | CLIP**          |             |       |
|---------------------------------|--------------|--------------|-------------|-------|-----------------|-------------|-------|
|                                 |              | DRAWING      | MATERIAL    | COLOR | DRAWING         | MATERIAL    | COLOR |
| T50RMOC10SAD-SET-PA66HIRHSUV-BK | 4 TO 50      | CT2050007CST | PA66HIRHSUV | BLACK | 16-0318-008-CSU | PA66HIRHSUV | BLACK |

|   |                                     |             |  |  |           |           |                 |                                      |        |                |         |
|---|-------------------------------------|-------------|--|--|-----------|-----------|-----------------|--------------------------------------|--------|----------------|---------|
| Material<br>SEE CHART<br>COLOR: SEE CHART | Units                               | millimeters | The copyright of this drawing is reserved by HellermannTyton. It is issued on condition that it is not reproduced, copied or disclosed to a third party, either wholly or in part, without the consent of HellermannTyton. | Drawn  | TAT       | 11/5/2018 | Article/Type-No | T50RMOC10SAD                         |        | Scale          | 1:2     |
|   | Tolerance defined on each dimension | Approved    |  | EJH  | 11/5/2018 | Title     |                 | 10MM (7/16") MOC WITH T50R CABLE TIE |        | Project Number | 16-0318 |
|   |                                     |             |  | <br>North America<br>Web: www.hellermann.tyton.com |           |           | Drawing-No      | PRODUCTION : Phase                   | Format | AH             |         |
|   |                                     |             |  |  |           |           | 16-0318-108-CSU |                                      | Sheet  | 1/1            |         |